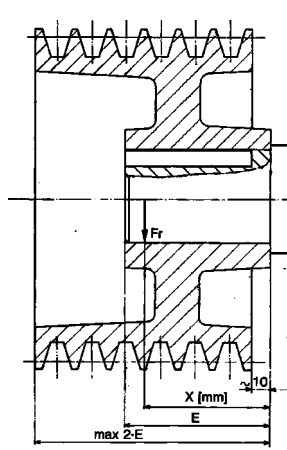

Pacco Lenght	Max potenza eccitazione Max excitation power	Momento di inerzia Moment of inertia	Dimensioni spazzole Brushes dimensions	Cuscinetto lato accoppiamento Drive end bearing		Cuscinetto lato collettore No-drive end bearing	Peso Weight
				Sfere Balls	Rulli Rollers		
	W	Kg · m ²	mm				Kg
S	230	0.0085	16x10x25	6206 - 2Z	NU 206	6305 - 2Z	54
M	255	0.0124					65
L	285	0.0176	72				
P	310	0.0247	78				
			16x20x32				

Dati ventilazione Ventilation		Elettroventilatore Electrofan		Rumorosità Noise
Portata Air flow	Prevalenza Pressure	Potenza Power	I a 380 V I at 380 V	
m ³ /h	mm H ₂ O	Kw	A	dB _A
300	55	0.18	0,7	71

Carico radiale (Newton) ammissibile per una durata teorica del cuscinetto lato accoppiamento di 20.000 ore
Admitted radial load (Newton) for a theoretic 20.000 hours of the drive end bearing

	rpm	200	400	600	1000	1200	1500	2000	2500	3000	3500	4000	5000		
		6206 - 2Z	X	Fr (N)											
			0	2500	1930	1650	1320	1230	1120	970	870	820	760	630	630
20	2370		1820	1550	1240	1160	1050	900	820	770	700	660	600		
40			1700	1420	1160	1080	1000	850	770	720	660	620	550		
60				1380	1100	1030	920	800	720	670	620	500	520		
NU 206	X	Fr (N)													
	0	3600	2850	2520	2080	1920	1780	1630	1500	1410	1330	1260	1150		
	20	3400	2700	2380	1950	1850	1700	1530	1420	1330	1250	1190	1080		
	40				1840	1750	1600	1440	1330	1240	1180	1110	1020		
	60						1520	1350	1250	1170	1100	1050	930		
80															

MM 90 S

	VELOCITÀ [rpm] ALLE TENSIONI						P [kw]	I [A]	η [%]	ARMATURA	
	160V	220V	260V	330V	400V	440V				L [mH]	R _{115°} [Ω]
D	3040						5.2	40	0.807	3.5	0.45
E	2610						4.3	34.1	0.793	4.6	0.59
		3750					6.2	34.1	0.828		
F	2270						3.8	30.3	0.774	5.9	0.77
		3280					5.4	30.3	0.815		
G	2000						3.3	27.3	0.756	7.2	0.96
		2910					4.8	27.3	0.802		
			3520				5.8	27.3	0.821		
H	1780						2.9	24.7	0.742	8.8	1.2
		2610					4.3	24.7	0.792		
			3170				5.2	24.7	0.812		
I	1600						2.7	23.2	0.727	10	1.4
		2360					4.0	23.2	0.781		
			2870				4.8	23.2	0.803		
				3750			6.4	23.2	0.829		
J	1450						2.4	21.1	0.715	12	1.6
		2160					3.6	21.1	0.772		
			2620				4.4	21.1	0.795		
				3440			5.7	21.1	0.823		
K	1320						2.2	19.3	0.698	14	1.9
		1970					3.2	19.3	0.759		
			2410				3.9	19.3	0.785		
				2170			5.2	19.3	0.814		
L	1200						1.9	17.6	0.678	16	2.3
		1810					2.9	17.6	0.745		
			2210				3.5	17.6	0.772		
				2920			4.7	17.6	0.804		
				3630			5.8	17.6	0.824		

	VELOCITÀ [rpm] ALLE TENSIONI						P [kw]	I [A]	η [%]	ARMATURA	
	160V	220V	260V	330V	400V	440V				L [mH]	R _{115°} [Ω]
M	1110						1.8	17.1	0.672	19	2.4
		1680					2.8	17.1	0.741		
			2060				3.4	17.1	0.769		
				2730			4.5	17.1	0.802		
					3390		5.6	17.1	0.823		
						3770	6.3	17.1	0.832		
N	950						1.6	15.2	0.646	24	3.0
		1460					2.4	15.2	0.722		
			1800				3.0	15.2	0.753		
				2390			4.0	15.2	0.789		
					2980		4.9	15.2	0.813		
						3320	5.5	15.2	0.823		
O		1270					2.1	13.7	0.700	29	3.7
			1580				2.6	13.7	0.734		
				2110			3.5	13.7	0.774		
					2640		4.4	13.7	0.800		
						2950	4.9	13.7	0.812		
P		1180					1.9	12.6	0.679	32	4.3
			1470				2.4	12.6	0.717		
				1980			3.2	12.6	0.760		
					2480		4.0	12.6	0.789		
						2770	4.5	12.6	0.801		
Q		1120					1.8	12.3	0.675	35	4.5
			1400				2.3	12.3	0.714		
				1880			3.1	12.3	0.758		
					2360		3.9	12.3	0.787		
						2640	4.3	12.3	0.799		
R		980					1.6	11.2	0.649	42	5.6
			1240				2.0	11.2	0.691		
				1680			2.7	11.2	0.704		
					2130		3.5	11.2	0.772		
						2380	3.9	11.2	0.785		
S			990				1.6	10	0.622	53	8.2
				1390			2.2	10	0.686		
					1780		2.9	10	0.727		
						2010	3.3	10	0.745		
T			900				1.5	8.8	0.630	65	9.0
				1260			2.0	8.8	0.692		
					1620		2.6	8.8	0.732		
						1820	2.9	8.8	0.749		
U					1110		1.9	8.4	0.674	79	10.2
						1440	2.4	8.4	0.719		
						1620	2.7	8.4	0.737		

MM 90 P

	VELOCITÀ [rpm] ALLE TENSIONI						P [kw]	I [A]	η	ARMATURA	
	160V	220V	260V	330V	400V	440V				L [mH]	R ₁₁₅ [Ω]
A	2780						54	40	0.839	1.8	0.28
		3920					7.5	40	0.853		
B	2170						5.4	40	0.837	2.9	0.37
		3090					7.6	40	0.860		
			3700				9.0	40	0.867		
C	1760						5.2	40	0.821	4.2	0.48
		2520					7.5	40	0.852		
			3030				9.0	40	0.865		
				3910			11.5	40	0.877		
D	1440						4.9	39.2	0.792	5.7	0.64
		2090					7.2	39.2	0.834		
			2530				8.7	39.2	0.851		
				3290			11.2	39.2	0.869		
E	1240						4.1	33	0.776	7.5	0.83
		1810					5.9	33	0.823		
			2190				7.2	33	0.842		
				2860			9.4	33	0.862		
F	1060						3.5	29.3	0.749	9.5	1.1
		1570					5.2	29.3	0.804		
			1910				6.3	29.3	0.826		
				2500			8.2	29.3	0.851		
G	930						3.0	26.4	0.724	12	1.4
		1380					4.6	26.4	0.787		
			1690				5.6	26.4	0.812		
				2220			7.3	26.4	0.840		
H	820						2.7	23.9	0.705	14	1.6
		1240					4.1	23.9	0.773		
			1510				5.0	23.9	0.800		
				2000			6.5	23.9	0.832		
I							8.1	23.9	0.851	17	1.9
							9.0	23.9	0.859		
		1100					3.7	22.4	0.756		
			1360				4.6	22.4	0.786		
							6.1	22.4	0.821		
							7.5	22.4	0.843		
							8.4	22.4	0.852		

	VELOCITÀ [rpm] ALLE TENSIONI						P [kw]	I [A]	η	ARMATURA	
	160V	220V	260V	330V	400V	440V				L [mH]	R ₁₁₅ [Ω]
J										20	2.2
		1010					3.3	20.4	0.746		
			1240				4.1	20.4	0.777		
				1650			5.5	20.4	0.814		
					2060		6.8	20.4	0.837		
K										23	2.6
		910					3.0	18.6	0.728		
			1130				3.7	18.6	0.763		
				1510			4.9	18.6	0.803		
					1890		6.2	18.6	0.828		
L										26	3.2
				1040			3.3	17	0.747		
					1390		4.4	17	0.790		
						1750	5.6	17	0.818		
						1950	6.2	17	0.829		
M										30	3.4
				960			3.2	16.5	0.741		
					1290		4.3	16.5	0.786		
						1630	5.4	16.5	0.815		
						1820	6.0	16.5	0.827		
N										38	4.2
				830			2.7	14.7	0.718		
					1120		3.7	14.7	0.768		
						1420	4.7	14.7	0.801		
						1590	5.2	14.7	0.814		
O										47	5.2
				980			3.3	13.2	0.747		
					1250		4.1	13.2	0.784		
						1400	4.6	13.2	0.799		
P										52	6.1
					920		2.9	12.2	0.729		
						1170	3.7	12.2	0.768		
						1320	4.2	12.2	0.785		
Q										57	6.4
						1110	3.6	11.9	0.765		
						1250	4.1	11.9	0.7682		

I dati riportati fanno riferimento a motori: *The data shown refer to motors:*

- con ventilazione assistita addossata PVA *- with assisted leaning ventilation PVA*
- in servizio continuo CEI S1 *- in continuous service CEI S1*
- con alimentazione con fattore di forma = 1 *- with form factor = 1*
- con temperatura massima ambiente 40 °C *- with maximum room temperature 40 °C*
- con altitudine s.l.m. max 1000 m. *- with maximum height above sea level 1000 m.*

2117/B

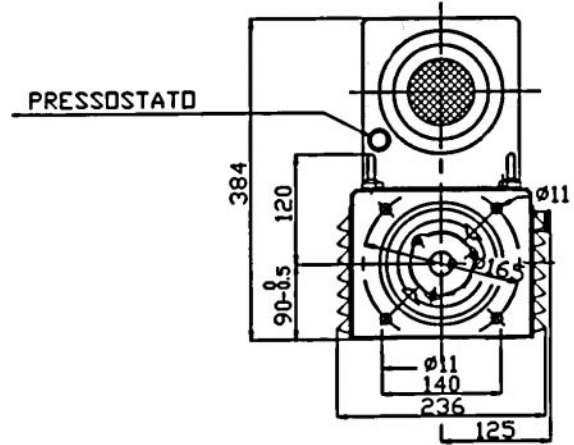
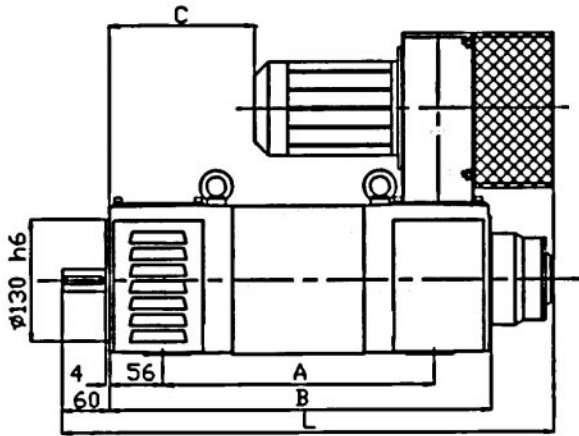

2118/B

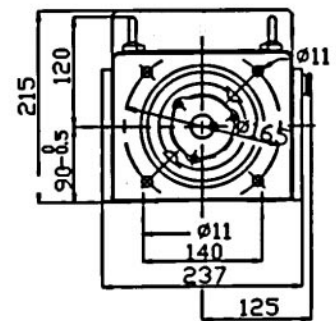
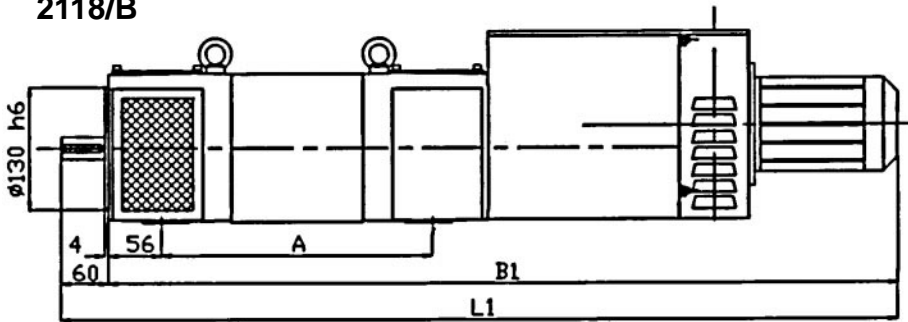

2119/B

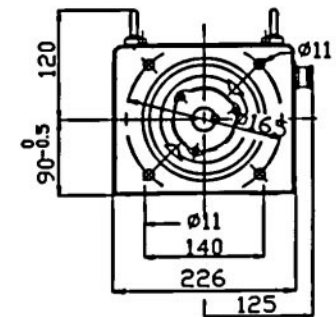
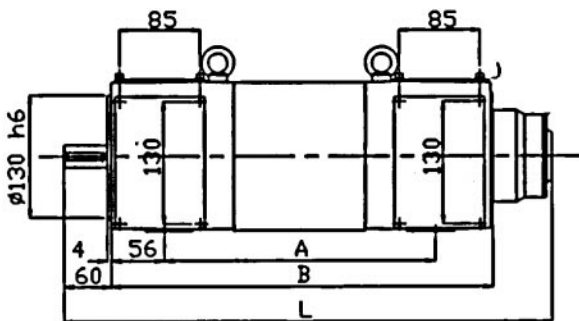

Tipo Type	Ingombro massimo / Max overall						
	A	B	B1	C	L	L1	
90	S	250	365	830	85	485	890
	M	280	395	860	115	515	920
	L	310	425	890	145	545	950
	P	340	455	920	175	575	980

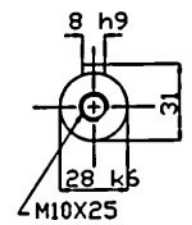

La MAGNETIC si riserva la facoltà di cambiare senza preavviso i dati contenuti nel presente catalogo. / MAGNETIC reserves the right to change any data contained in this catalogue, without previous notice.



MAGNETIC SpA
 Sede Amm.va e Stabilimento:
 Via Fracanzana, 14
 36054 Montebello Vicentino (VI) Italy
 Tel. (0444) 649399
 Fax (0444) 440495
 E-mail: info@magneticspa.it
 Web site: www.magneticspa.it